

**NULINE**  
REFRIGERATION

**FLUID WARMER**  
Warranty, Installation,  
Maintenance & Operational  
Manual



+61 3 9562 3355  
info@nuline.au  
[www.nuline.au](http://www.nuline.au)

# CONTENTS

## Introduction

<i>Your New Nuline Cabinet</i> .....	3
<i>Disclaimer</i> .....	3
<i>Warranty</i> .....	3
<i>General and Safety Precautions</i> .....	4

## Product Overview

<b>Cabinet Description</b> .....	6
<i>FW100</i> .....	6
<i>FW250</i> .....	7
<i>FW650</i> .....	8
<i>FW1100</i> .....	9
<b>Silver Information Label</b> .....	10
<b>Specifications</b> .....	11

## Installation

<b>Setting Up</b> .....	12
<i>Handling</i> .....	12
<i>Unpacking</i> .....	12
<i>Positioning</i> .....	13
<b>Electrical Connection</b> .....	16
<b>Shelves</b> .....	17
<i>Adjustable Shelf Installation</i> .....	17
<i>Loading Restrictions</i> .....	17
<b>Temperature Probes</b> .....	18
<b>Port Entry</b> .....	19
<b>Remote Alarm Contact</b> .....	20

## Operation

<i>Microprocessor Controller</i> .....	21
<i>Initial Start Up</i> .....	22
<i>Alarm Set Points</i> .....	22
<i>Temperature Adjustment</i> .....	22
<i>Parameter Table</i> .....	23

## Maintenance

<b>Preventative Maintenance</b> .....	24
<i>Cleaning</i> .....	24
<b>Troubleshooting</b> .....	27
<i>Troubleshooting Procedures</i> .....	27
<i>Spare Parts</i> .....	27
<b>Inactivity for Extended Period</b> .....	28
<b>Disposal</b> .....	29



### WARNING

If the cabinet is not working as it should on first use please contact us right away and do not use the cabinet.

# INTRODUCTION

## Your New Nuline Cabinet

Thank you for choosing a Nuline cabinet please read through the warranty, manual and specifications of your cabinet carefully to become familiar with your new cabinet.

Our cabinets are designed and manufactured to meet the specialized needs of the biomedical industry. With correct care and maintenance in accordance with these instructions, your new cabinet will provide many years of reliable service.

Nuline Refrigeration has been manufacturing refrigerators and freezer cabinets in our Melbourne factory for the Australian market since 1985. Our specialized range of biomedical cabinets that are Australian made and imported from selected global suppliers, are used extensively across hospitals, medical centres, pharmacies, and laboratories.

**Carefully read this instruction booklet, as it contains important advice for safe installation, operation, and maintenance. Keep this booklet on hand in a safe place for future reference by other users.**

### Disclaimer

Nuline refrigeration cabinets are designed for the storage of cooled, chilled or frozen biomedical products, such as vaccines, laboratory samples, and, but not limited to pharmaceutical drugs and medication.

The use of Nuline cabinets for any other application is not warranted unless subject to prior approval by Nuline. The cabinets are designed specifically to store products that are already cooled, chilled or frozen to the required temperature.

The cabinets are not designed to be ordinarily switched off as bacteria growth, mould, odours, rust, or water overflow could occur.

Transportation of the cabinet must be always done with the cabinet upright, do not lay the cabinet on sides, front, or back.

### Warranty

Our warranty can be found on our website at [www.nuline.au](http://www.nuline.au) and alternatively you can scan this QR code.



# INTRODUCTION

## General and Safety Precautions

To prevent personal and material injury when using any electrical cabinets, safety precautions must always be observed.

Our cabinets have been designed for high performance. The cabinet must be used exclusively for the purpose for which it has been designed for.

Read and understand this manual, if in doubt contact Nuline Refrigeration.

- All cabinets **MUST** be installed according to the procedures stated in the installation section of this manual.
- In the case of new personnel, training is to be provided before operating the cabinet.
- **DO NOT** use this cabinet for any other purpose than its intended use.
- **DO NOT** store explosive substances such as aerosol cans with a flammable propellant in or near this cabinet.
- Keep fingers out of "pinch point" areas.
- The cabinet is not waterproof **DO NOT** use jet sprays, hoses or pour water over / on the exterior of the cabinet.
- Only use this cabinet with voltage specified on the rating label.
- **DO NOT** remove any cover panels that may be on the cabinet.
- **DO NOT** use sharp objects to activate controls.
- **DO NOT** use sharp objects to remove ice from the cabinet.
- If any fault is detected, refer to troubleshooting.
- This appliance is **NOT** suitable for storing and cooling blood, blood plasma or similar substances. Any misuse of the appliance may result in damage to or spoilage of stored goods.
- **DO NOT** allow naked flames or ignition sources to enter the appliance.
- **DO NOT** stand on the drawers, shelves or doors or use them to support anything else.

# INTRODUCTION



- **DO NOT** insert metal objects such as a wire into any vents, gaps, or any outlet on the cabinet. This may cause electric shock or injury by accidental contact with moving parts.
- When connecting and disconnecting the appliance, pull on the plug, not on the cable. Pulling on the cable has the potential to damage the cable, this could result in electric shock or fire by short circuit.
- This appliance is not suitable for operations in outdoors or areas where it is exposed to splash water or damp conditions.
- This appliance is not suitable for operation in potentially explosive atmospheres.
- Keep the cabinet and surrounding areas clean, dry, and uncluttered.
- The manufacturer declines any liability for damages to persons and / or things due to an improper / wrong and / or unreasonable use of the machine as well any failure of the refrigeration system.
- Only specifically trained / qualified Technicians (one of our service agents, or a similarly qualified persons) should carry out all repairs, maintenance, and services.
- Disconnect the power cord if there is something wrong with the cabinet.
- Nuline Refrigeration will not be held liable for any potential loss of stock due to failure of the refrigeration system and / or any other failure of the cabinet.

# PRODUCT OVERVIEW

## Cabinet Description

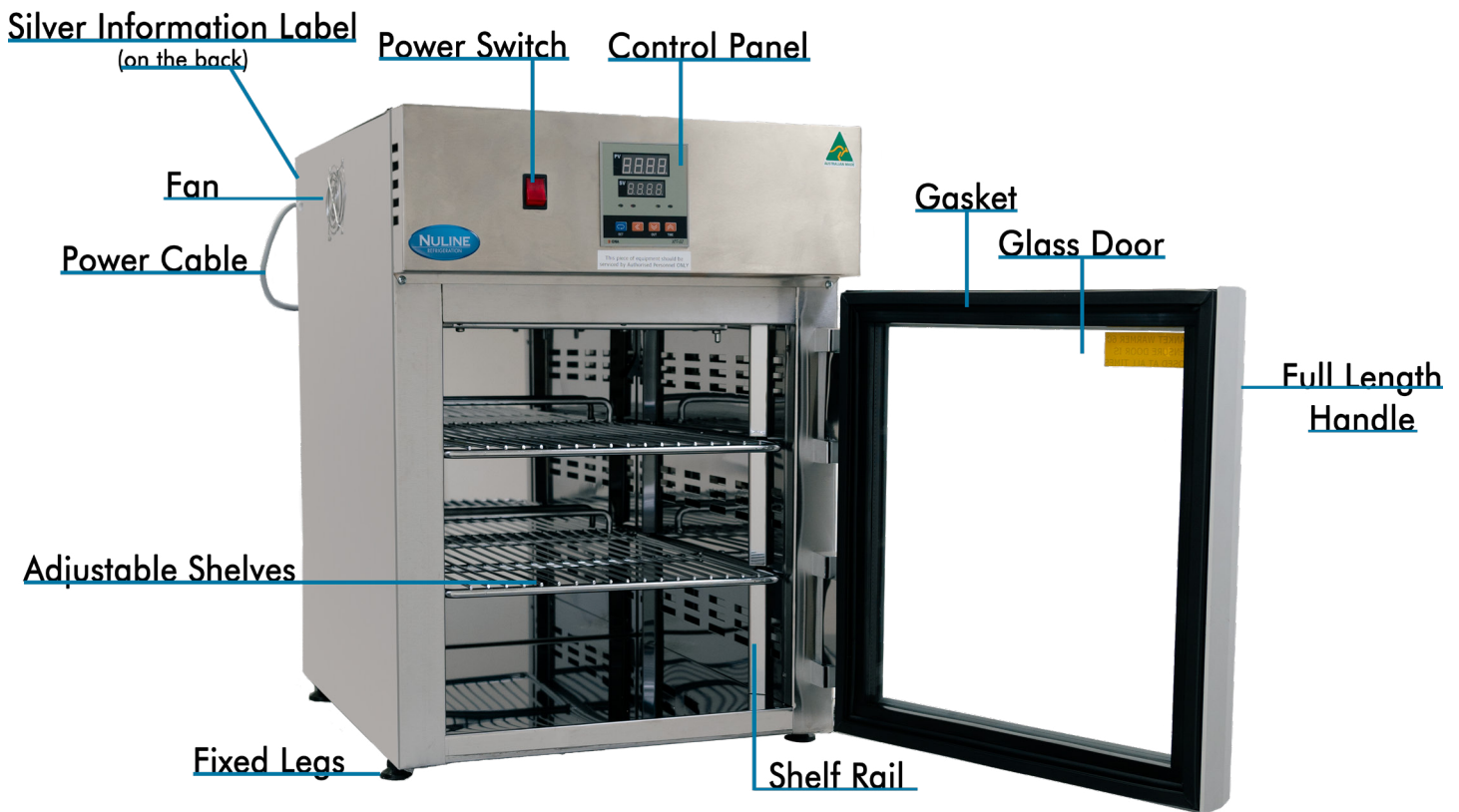
**FW100**





	<b>IMPORTANT</b>
	<p>This unit is only designed to maintain the product at the controlled temperature.</p>
	<b>CAUTION</b>
	<p>This unit includes heating components. Take care when placing and removing products.</p>

# PRODUCT OVERVIEW

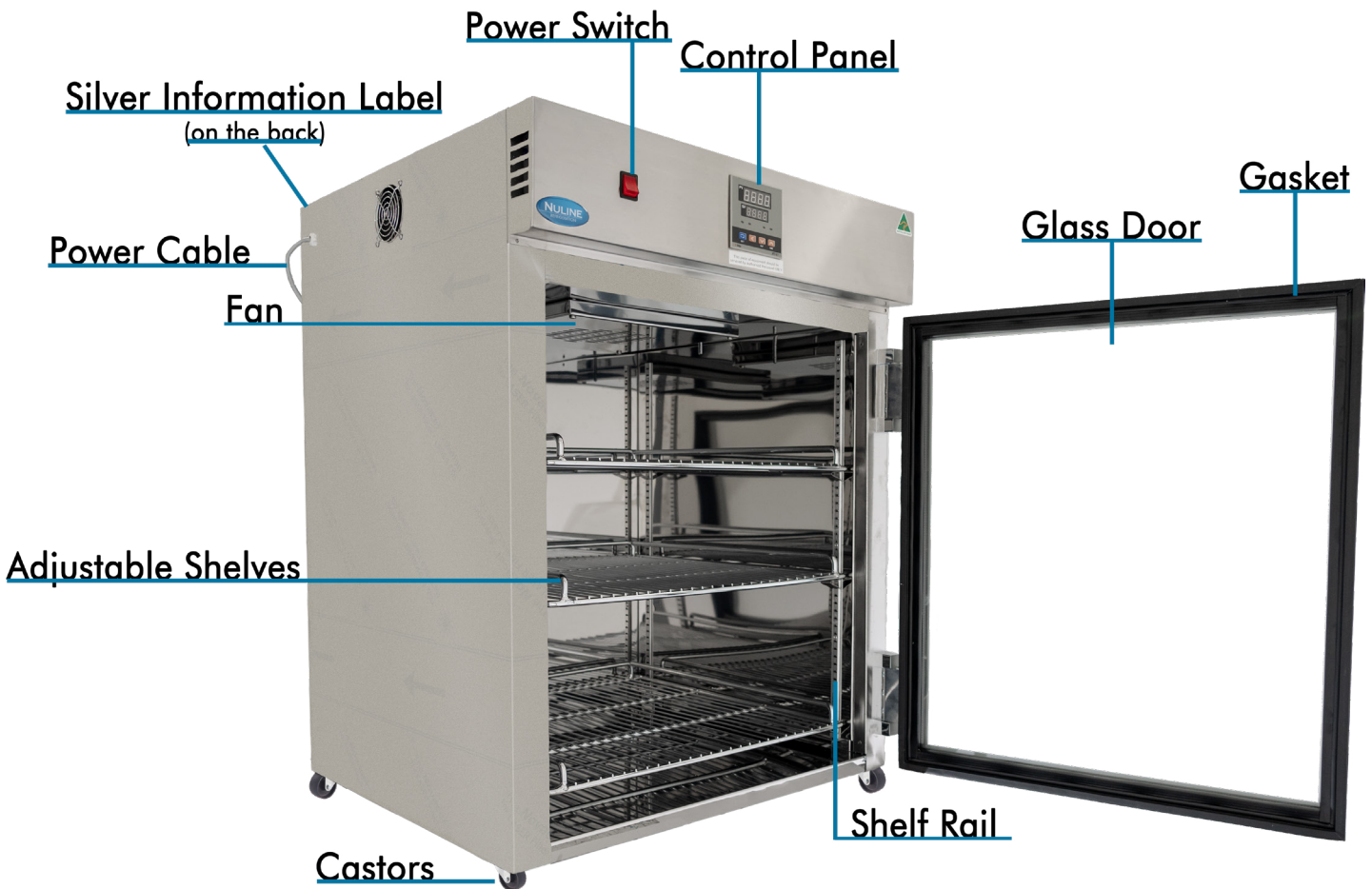
## FW250





	<b>IMPORTANT</b>
	This unit is only designed to maintain the product at the controlled temperature.
	<b>CAUTION</b>
	This unit includes heating components. Take care when placing and removing products.

# PRODUCT OVERVIEW

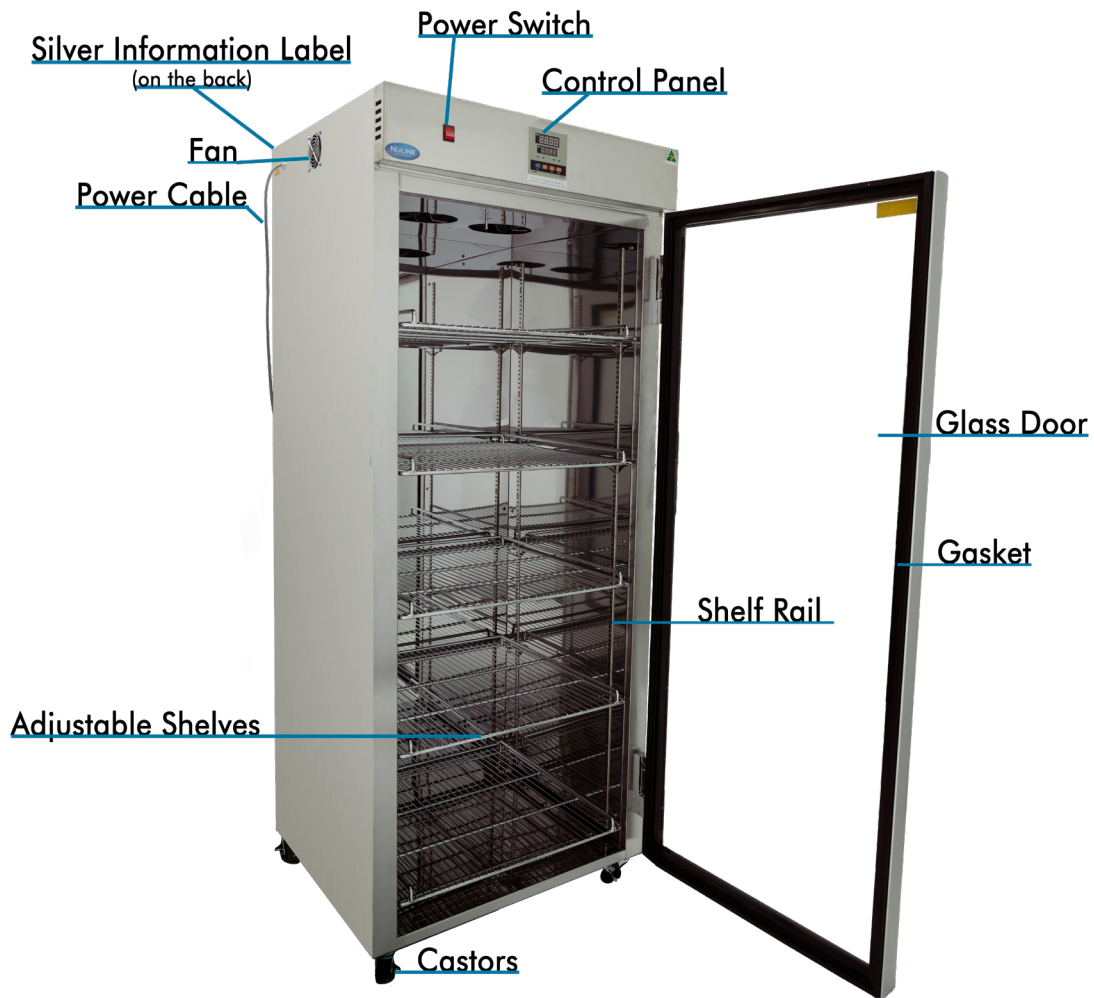
## FW650



	<b>IMPORTANT</b>
	<p>This unit is only designed to maintain the product at the controlled temperature.</p>
	<b>CAUTION</b>
	<p>This unit includes heating components. Take care when placing and removing products.</p>

# PRODUCT OVERVIEW

## FW1100

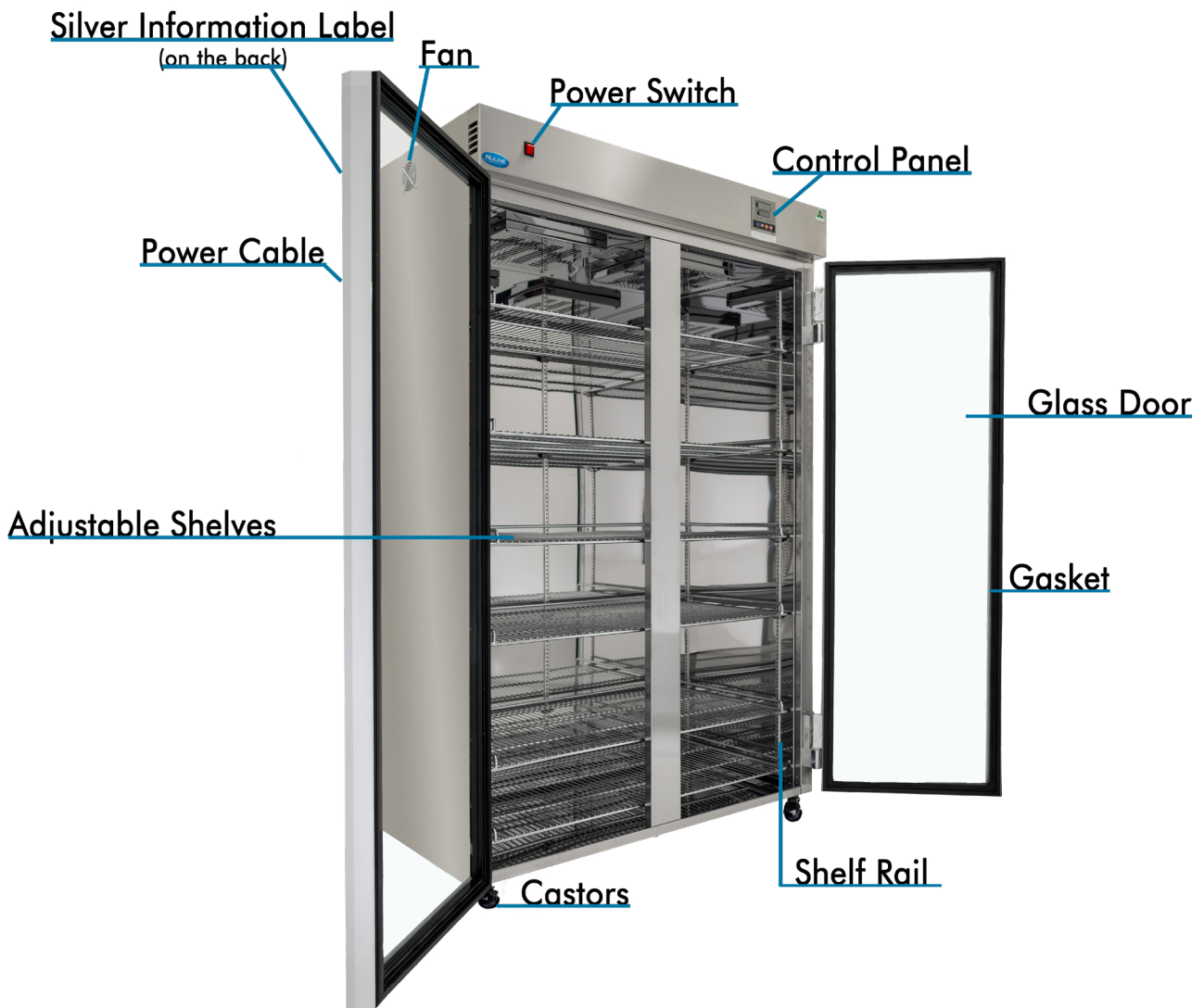

### IMPORTANT

This unit is only designed to maintain the product at the controlled temperature.



### CAUTION

This unit includes heating components. Take care when placing and removing products.

## PRODUCT OVERVIEW

### Silver Information Label

The silver information label is placed on the back of the cabinet.

#### NULINE REFRIGERATION

Model	<b><i>FW650</i></b>
Serial No.	<b>18074</b>

<b>Voltage</b>	<b>220-240</b>	<b>VOLT</b>
<b>Frequency</b>	<b>50</b>	<b>HZ</b>
<b>Power</b>	<b>1320</b>	<b>WATTS</b>
<b>Light</b>	<b>-</b>	<b>WATT</b>
<b>Element</b>	<b>2 x 600</b>	<b>WATT</b>
<b>Range</b>		<b>WATT</b>
<b>Capacity</b>		<b>LITRES</b>
<b>Refrigerant</b>		<b>KG</b>

NULINE  
T: (03) 9562 3355  
E: [info@nuline.au](mailto:info@nuline.au)

# PRODUCT OVERVIEW

## Specifications

Model	FW100	FW260	FW650	FW1100
Gross Capacity	80 L	247 L	611 L	1000 L
External Dimensions in mm (w/d/h including castors)	500 x 600 x 625	700 x 700 x 972	750 x 700 x 1880	1200 x 700 x 1880
Internal Dimensions in mm (w/d/h)	390 x 480 x 370	590 x 685 x 600	630 x 610 x 1590	1100 x 550 x 1555
Packed Dimensions in mm (w/d/h including pallet)	575 x 670 x 765	800 x 800 x 1070	850 x 800 x 2030	1300 x 800 x 2030
Gross Weight - kg (packed weight)	63	109	180	260
Net Weight - kg	48	89	160	220
Voltage	240V			
Temperature Set	35°C			
Temperature Range	Ambient +5°C to 60°C			
Exterior Cabinet Finish	Stainless Steel			
Inner Liner Material	Stainless Steel			
Door	Glass			
Door Hinge	RH		LH / RH	
Door Handle	Full Length			
Type of Controller	Microprocessor			
Temperature Display	Digital			
BMS Connectivity				
(BMS Connectivity for Remote Alarms only)			Optional	
(BMS Connectivity for 4-20mA Transmitter)			Optional	
Port Entry	Optional			
Power Requirement	10amp GPO			
Castors	Fixed Legs		Yes	
Adjustable Shelves	2	3	5	6

# INSTALLATION

## Setting Up



### **WARNING**

Improper installation, adjustments, alternations, service, or maintenance can cause property damage, injury, or death.

## Handling

- To prevent injury or damage to the unit, take the proper precautions when moving the cabinet.
  - For smaller cabinets have two people.
  - For larger cabinets moving equipment such as a forklift or pallet trolley should be used (the forks should be completely under the pallet).
- Ensure that the cabinet is always level.

## Unpacking

- Before and after unpacking, the cabinet should be checked for damage.
- If there is any damage, contact the distributor and/or manufacture within 24-48 hours of receipt and before connecting to the mains.
- The cabinet is supplied fully assembled.
- Remove all protective plastic film, tapes, ties, and packers before installing and operating.
- Clean off any residual from the interior / exterior / all shelves of the cabinet using a clean cloth and warm soapy water.
- Adjust all shelves as you require.



### **WARNING**

Danger of suffocation due to packing material and plastic film.  
Do not allow children to play with packaging material.  
Take the packaging material to an official collection point.

# INSTALLATION

## Positioning

1. Ensure that the cabinet is on a horizontal and level floor.
  - If your cabinet comes with front levelling feet, you may adjust them to ensure the cabinet is level.
  - If the cabinet is on castors the front two breaks on the castors must be engaged to ensure the cabinet stays in the correct position.
2. Do not position the cabinet in:
  - Wet areas
  - Near heat and / or steam sources
  - Near flammable substances
3. Ensure there is 60mm ventilation space on sides, 30mm at rear and 200-300 mm on top of for proper air flow for the larger cabinets.
4. Ensure there is 60mm ventilation space on sides, 30mm at rear and 60mm on top of for proper air flow for the smaller cabinets.
5. The cabinet should not be installed in any manner that would impede normal service access.
6. We recommend the cabinet runs for 24hrs prior to loading to enable the internal temperature to stabilise accordingly.



### **WARNING**

This is a warming cabinet, take care not to hold or touch for a prolonged period of time areas that heat as this could result in an injury / burn.

# INSTALLATION

## Large Cabinets

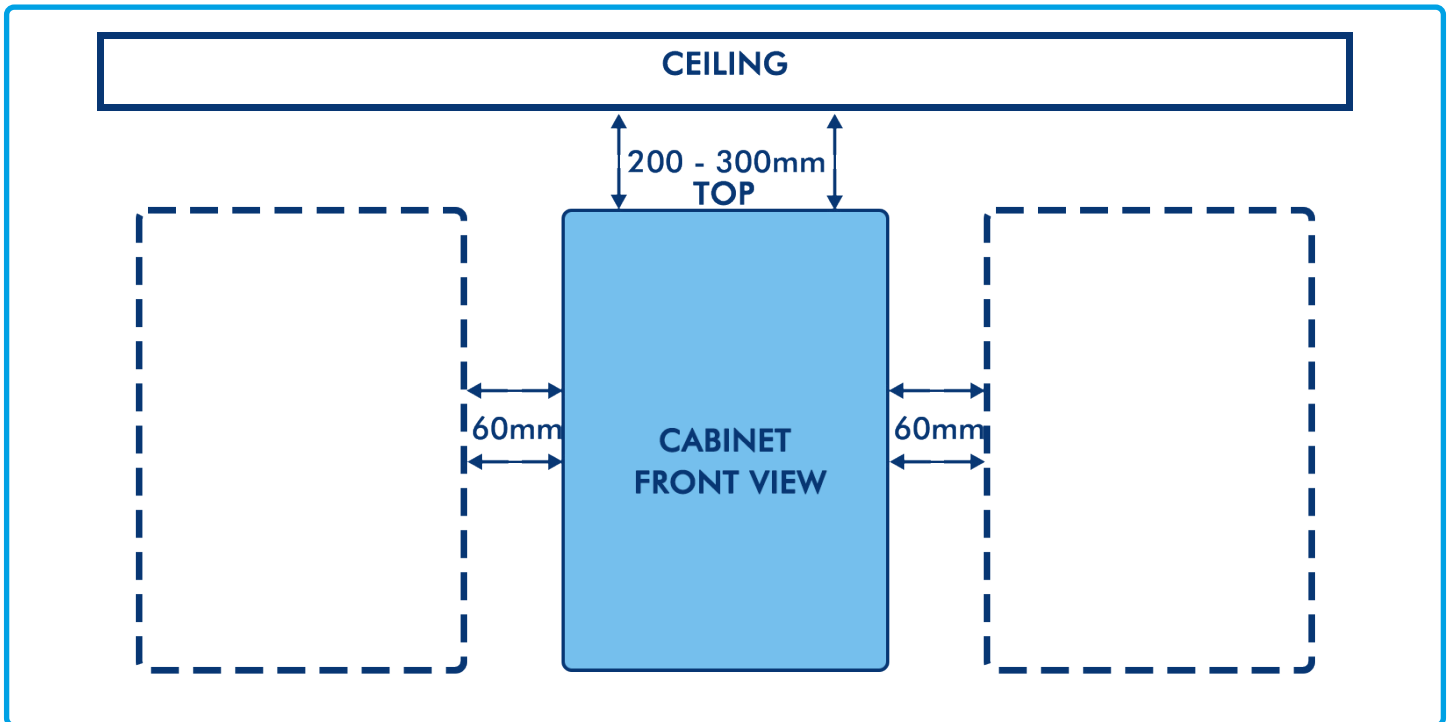
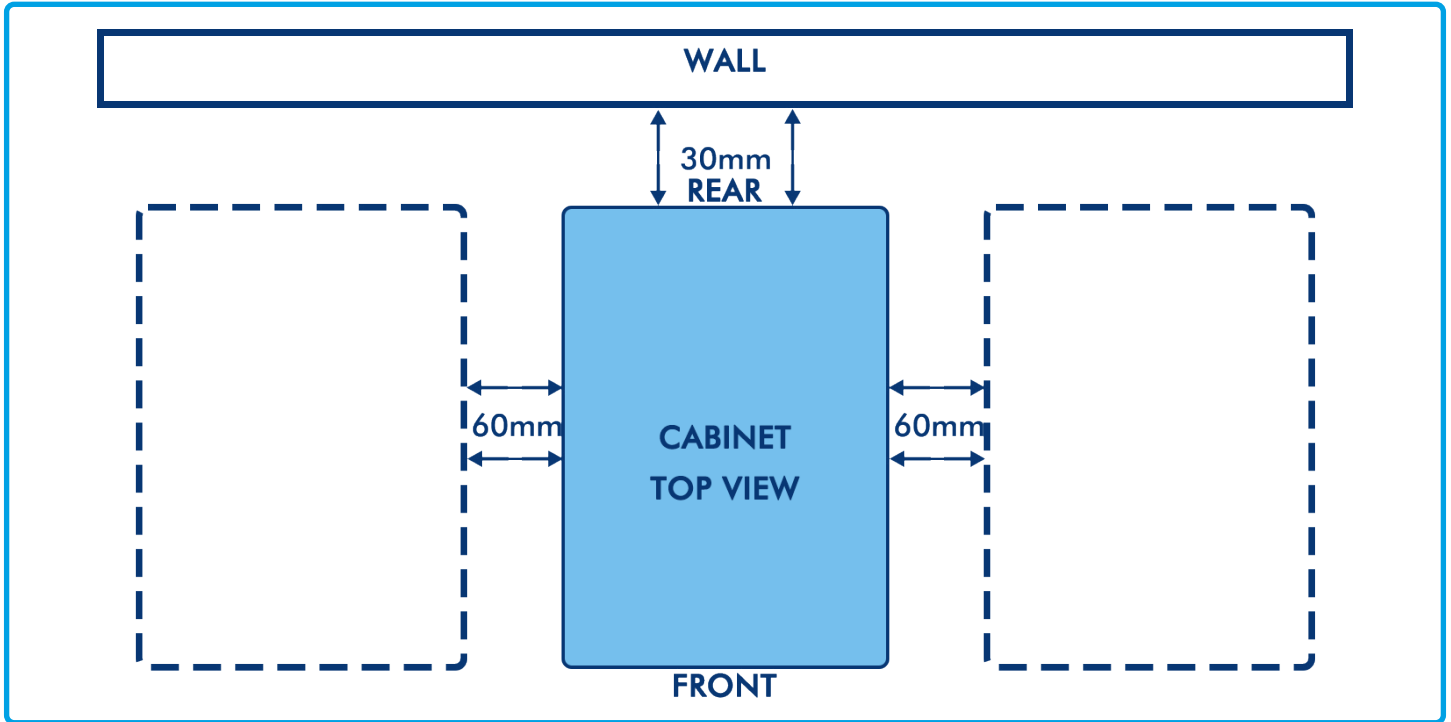

# INSTALLATION

## Small Cabinets

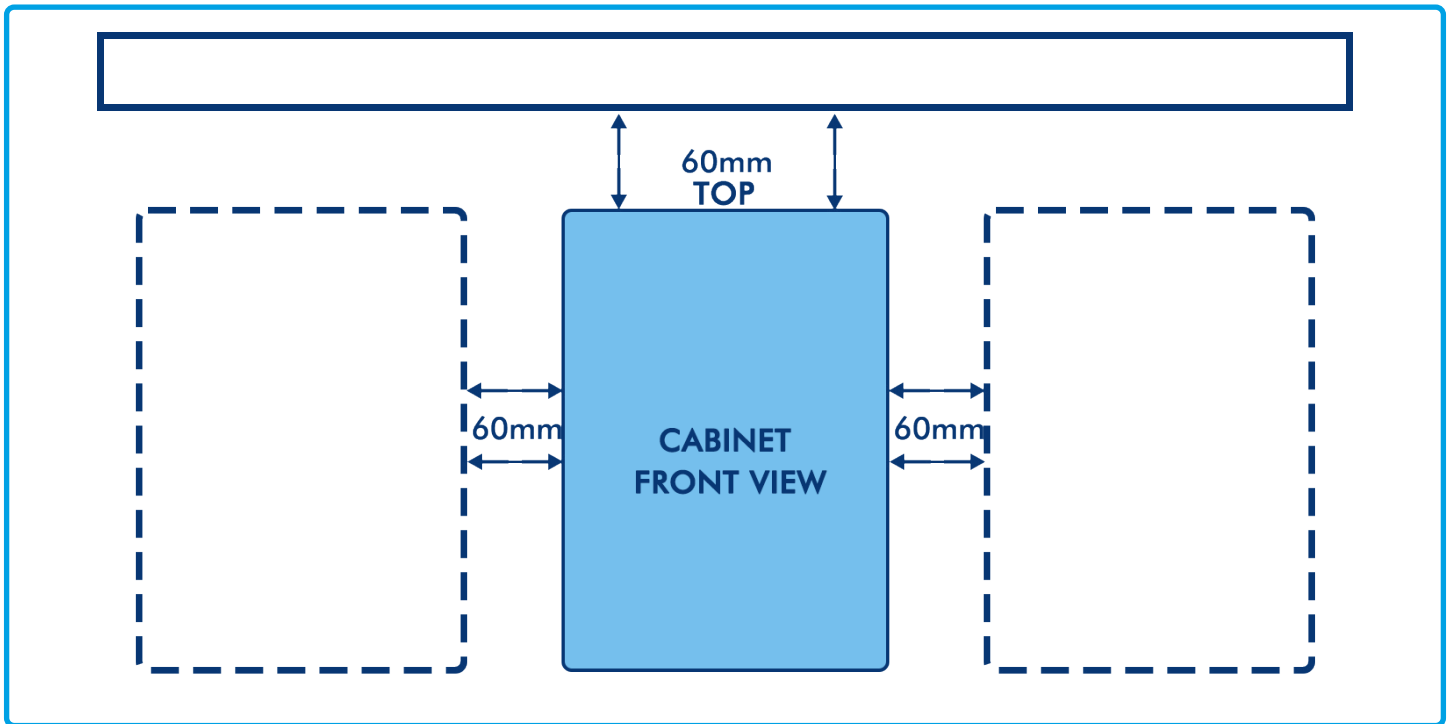
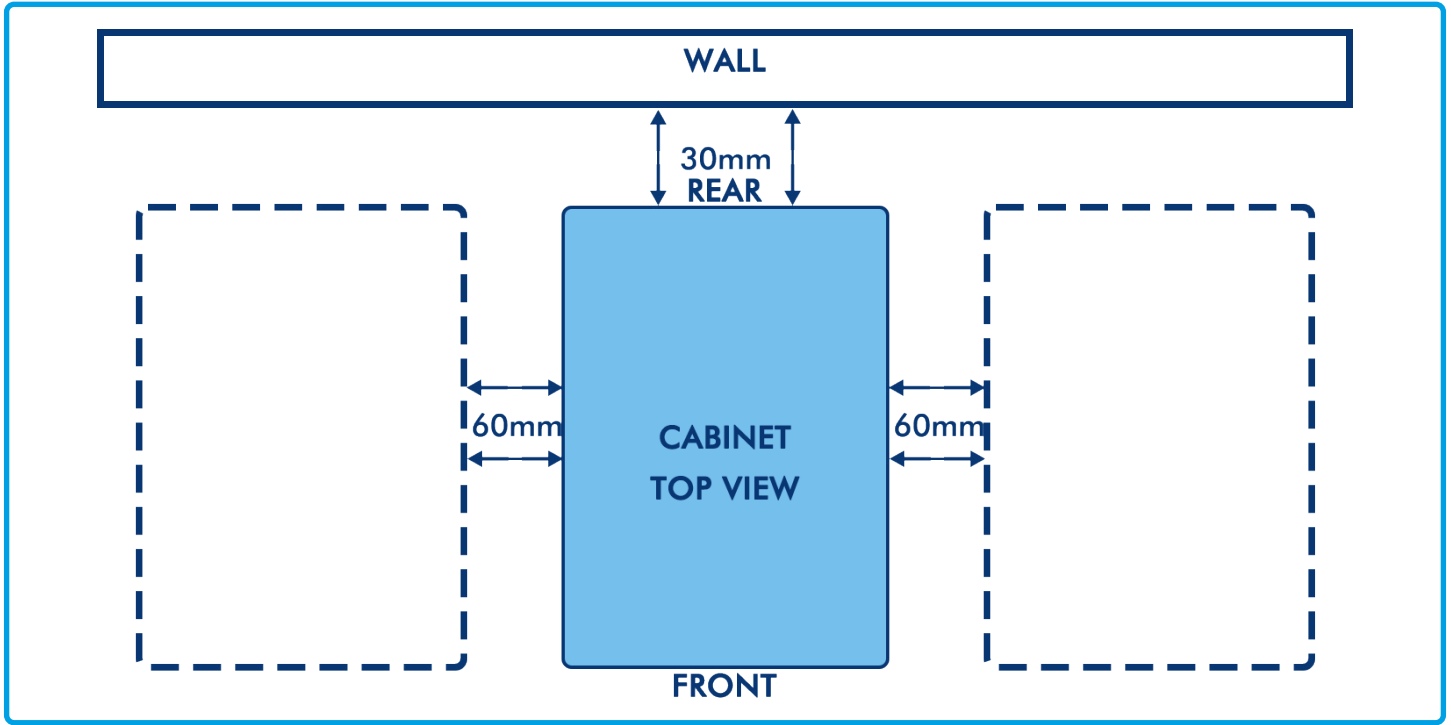

# INSTALLATION

## Electrical Connection

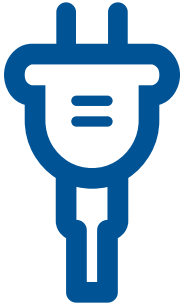

### WARNING

Some procedures in this manual require the power to the equipment to be turned off and isolated. Turn the power OFF at the power point and unplug the power supply lead by the plug body. If the power point is not readily accessible turn the equipment off at the isolation switch or the circuit breaker in the switchboard. Attach a yellow "CAUTION-DO-NOT OPERATE" tag. This must be performed where relevant unless the procedures specify otherwise.  
**FAILURE TO DO SO MAY RESULT IN ELECTRIC SHOCK.**

### Single Phase Units:

Supplied and fitted with an appropriately rated plug and lead, 10A plug.

When connecting and disconnecting the appliance, pull on the plug, not on the cable.

### Notes:

If the supply cord is damaged, it must be replaced by the manufacture, its service agent, or similarly qualified persons in order to avoid a hazard. Please contact Nuline for parts and we will advise how to do this in order to avoid any electrical hazard.

The power cable should be dry and isolated from moisture and water.

# INSTALLATION

## Shelves

### Adjustable Shelf Installation

1. Fully open the door.
2. Lift up the shelf so that it is fully off the shelf support clips to remove the shelf.
3. Gently pull up to remove the shelf support clips
4. Push the shelf support clips down into the space on the shelving strips at the level that you desire.
5. Ensure that all four shelf support clips are at the same level.
6. Carefully lower the shelf inside the cabinet on top of the shelf support clips
7. Ensure that the shelf is fully inside the cabinet before loading and closing the door

When loading the shelves with product, care should be taken to ensure that the product is loaded evenly to allow for proper air circulation around all products.

Note: Do not use pliers when installing the shelf support clips

### Loading Restrictions

- There should NOT be any overhang of products on the shelves.
- Shelves are only designed to hold one layer of product. Overloading can break / damage the shelves and prevent proper air flow.
- Remove some products if the shelves are flexing or bending.
- Shelves should be adjusted to allow air space around all the product to ensure proper air flow and even refrigeration to ensure efficient operation of the cabinet.

## INSTALLATION

# Temperature Probes

This cabinet is equipped with a temperature probe inside the unit that monitors the temperature inside the cabinet. This probe also controls the temperature alarms. To monitor the temperature in various areas of the interior of the cabinet, external probes can be installed through the port entry if the cabinet has been built with one. The port entry is an option that needs to be specified when ordering the cabinet so that it can be installed during construction.

## INSTALLATION

### Port Entry

To monitor the temperature in various areas of the interior of the cabinet, external probes can be installed through the port entry. A port entry is optional on this cabinet, if it is required it should have been requested at the time of ordering the cabinet to ensure that a port entry can be installed during manufacturing.

#### Installation of External Probes

STEP 1



STEP 2



STEP 3

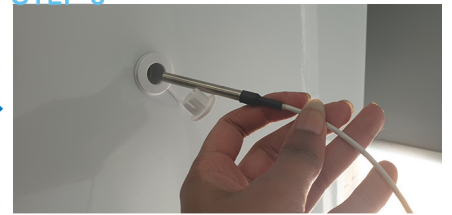

STEP 4



STEP 5



STEP 6



STEP 7



STEP 8



STEP 9



Never install probes through the door as this will prevent the door from closing properly, thus preventing a correct seal from forming and from preventing the cabinet from maintaining the correct temperature. This will damage the door gasket which will prevent a correct seal from forming.

Nuline Refrigeration will not be held liable for the damage caused by the incorrect installation of external probes out of the door.

## INSTALLATION

### Remote Alarm Contact

This cabinet is equipped with a voltage free remote alarm contact, which can be connected to a BMS system.

For installation simply connects the network cable from the BMS into the cabinet. We do not provide the network cable.

## OPERATION



### IMPORTANT

This unit is only designed to maintain the product at the controlled temperature range of an Ambient +5°C to 60°C.



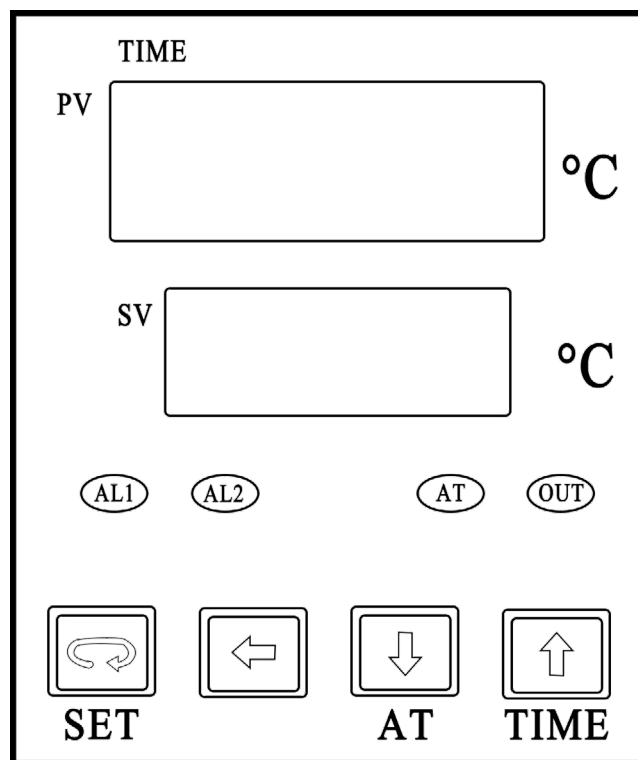

### Microprocessor Controller



The top display, PV displays the cabinet temperature.

The bottom display, SV displays the cabinet set temperature.

### Key Functions:

	SET functional key; revision of set value; call out of parameter symbols and confirmation of revised parameters
	Shift key; for shifting the set value or observing running fixed time
	Digital minus keys; for adjusting parameters or entry into self-adjustment state
	Digital plus keys; for adjusting parameters or entry into self-adjustment state

## OPERATION

### LED Indications:

<b>AL1</b>	Flashes when the internal temperature is lower than the set point.
<b>AL2</b>	Flashes when the internal temperature is higher than the set point.
<b>OUT</b>	Flashes when the cabinet is heating.

### Initial Start Up

- Before switching ON the cabinet, ensure the cabinet is installed correctly.
- Plug the cabinet into your 240-volt outlet and switch ON, the control panel will illuminate and start heating..
- After 2 hours check the cabinet temperature has reached it's set temperature. The **AL1** and **OUT** light will be on during the initial start-up, this is normal.
- Air vents must NOT be covered.

### Cabinet Temperature

- Ensure the cabinet is maintaining temperature at its set point.
- Ensure the doors are CLOSED when not loading to maintain temperature.

### Alarm Set Points

Should the temperature exceed the set points by +2°C, **AL2** will flash, the alarm will activate and power to the heating element will stop.

If the temperature falls below the set point, the **AL1** indicator light turn on.

### Temperature Adjustment

Temperature settings should only be carried out by a person with authority to do so.

- Push the set button
- Using the key pad to change the numbers and the shift key to move to the number to be changed
- Once you had reached new temperature settings, push set button to lock in the new set point.

## OPERATION

### Parameter Table

Parameter	Setting Range	Definition of Parameter	Setting of Leaving Factory
ST	1-9999 min	The setting value of timing	0
AL1	0-100% FS	The setting value of upper difference alarming (AL1)	5.0
AL2	0±1°C	The indicating setting of the blower fan	-5.0
SC	+20°C	The difference amending for the displaying value	0.0
ATU	0-1	Self adjusting commands (0: OFF, 1: ON)	0
P	0-100% (°C)	More Proportion, more P, lower the system plus, more stability, the precision of system is improved, eliminating the static difference	3.0
I	0-4320 sec.	Integral time, the I bigger, the integral smaller, which reducing the "Overshoot"	500
d	0-1200 sec	Differential coefficient time, generally is (1/4~1/5)	100
T	0-60	Cycle time, adopting controlled silicon as the output power, generally is 2~3 second.	2
HL/HL	0.50~1.500	Ensuring the temp display resolution which is unanimous in the range of testing.	1.000
OUT	(10-200)%%	The output power consumption can be adjusted when the heater showed the Proportional Band (P)	100
Lk	0-255	Locking (Lk=188(unlock) the numerical value can change, LK=0(lock) the numerical value can change)	18

# MAINTENANCE

## Preventative Maintenance

### Cleaning



#### WARNING

Never disassemble, repair, or modify the cabinet yourself. Any such work carried out by an unauthorized person may result in fire, or electric shock or injury due to a malfunction.

### General Information

- Cleaning is recommended for health and safety purposes and to prolong the life of the cabinet.
- **DO NOT** use abrasive pads or cleaners on the stainless steel or any other metal parts of the cabinet.
- **DO NOT** use industrial chemical cleaners, flammable cleaners, caustic-based cleaners or bleaches and bleaching agents, as many will damage the metals and plastics used on this cabinet.
- **DO NOT** remove any screws and / or panels for cleaning (unless directed)
- This unit is **NOT** waterproof, **DO NOT** hose, **DO NOT** pour water directly onto the unit, **DO NOT** immerse in water.
- Before performing maintenance or cleaning the unit, disconnect the electrical power supply.

### Corrosion Protection

- Stainless steel exhibits good resistance to corrosion however, if not properly maintained stainless steel can rust and / or corrode.
- Any sign of mild rust and / or corrosion should be thoroughly cleaned with warm soapy water and dried as soon as possible.
- NEVER use abrasive pads or cleaners for cleaning
- All metal surfaces should be checked while cleaning for damage, scuffs or scrapes as these can lead to rust and further damage to the cabinet.

# MAINTENANCE

- Mild rust and / or corrosion can be treated with a commercial cleaning agent that contains citric / oxalic / nitric / phosphoric acid. **DO NOT** use cleaning agents with chlorides or other harsh chemicals as this can cause corrosion. After treatment, wash with warm (not hot) soapy water and dry thoroughly.
- Thoroughly wipe the surfaces dry after cleaning. **DO NOT** let water pool on the unit. Check crevices and folds for pooling.
- When using, ensure all liquids and moisture is cleaned up straight away.
- **DO NOT** leave items on the stainless steel.

## Surface Finish

- To protect the polished surface of the stainless steel, it should be dried using a clean dry soft cloth.
- Some commercial stainless-steel cleaners can leave residue or film on the metal; this may trap fine particles from the air on the surface, thus deeming the surface not safe for medical products.



### WARNING

This unit is NOT waterproof, DO NOT hose. DO NOT pour water directly onto the unit. DO NOT immerse in water

## Cleaning Schedule

Regular cleaning, at least once a month is recommended for the cabinet. This will help to maintain and prolong the efficiency of the cabinet.

Wipe down all interior and exterior surfaces with a soft, dry cloth or a soft cloth dampened with warm soapy water. Wipe dry with a dry soft cloth to ensure that there's no water remaining on the cabinet.

If a thorough cleaning or disinfection is required, please follow the instructions below.

## Cabinet Interior

- Isolate the unit from the power supply.
- Remove shelves and wash separately, thoroughly wipe dry after cleaning.
- Using a good quality nylon brush remove any small particles.

# MAINTENANCE

- Clean using a clean cloth dampened with clean warm soapy water until all soil has been removed.
- Thoroughly wipe dry with a soft cloth after cleaning, do NOT allow to air dry. DO NOT let water to pool, check crevices and folds.

## **Door Seal**

- Using a clean cloth dampened with warm water, wipe down the door seal.

## **Glass Door**

- Clean the glass with a glass cleaner or warm soapy water, and a sponge.
- Using a squeegee, remove all water from the glass.

## **External Surfaces**

- Using a clean cloth dampened with clean warm soapy water until any grime has been removed.
- Using a clean sanitised cloth, thoroughly wipe the stainless steel and metal parts dry. Do NOT let water to pool on the cabinet. Check crevices and folds.

## **Ventilation Panels / Filter**

- Use a vacuum and / or brush to remove dust and debris from the filter and all ventilation panels.
- Do NOT use water or a hose to remove dust or debris.

# MAINTENANCE

## Troubleshooting

### Troubleshooting Procedures

- If any faults / issues occur with the unit, follow the below troubleshooting procedures.
- If the troubleshooting procedures do not correct the problem, contact us, Nuline Refrigeration.

PROBLEM	CAUSE	READY
Display not on	Power point not on On/off switch on unit is on Display board not on  Faulty on/off switch	Check to ensure if supply lead is plugged in  Faulty Board, call for assistance Call for assistance
Display panel on but not heating to correct temperature	Fan Failure	Turn power off and call for assistance
Display panel on but not heating	Faulty Element	Turn power off and call for assistance

### Spare Parts

For all spare parts requirements please contact Nuline Refrigeration with the cabinet's model number and serial number.

## MAINTENANCE

# Inactivity for Extended Period

Please take the following precautions when storing the cabinet for an extended period of time.

1. Clean both the interior and exterior of the cabinet
2. Ensure that the cabinet is completely dry.
3. Disconnect the power cord.
4. To prevent any rot and mould from forming, leave the door slightly ajar to allow air flow.

# MAINTENANCE

## Disposal

If the cabinet is no longer of use, please dispose in an environmentally correct way.

The distributor / retailer can contact their local metal recycling centre to collect the remaining cabinet, shelves, etc.

There may be special requirements or conditions. Information on the disposal of refrigeration appliances can be obtained from government authorities, (the local council, Ministry of the Environment, etc.)

Discarded electric appliances are recyclable and should not be discarded in the domestic waste. Please actively support us in conserving resources and protecting the environment by returning this appliance to the collection centres (if available).

Dispose of packaging in accordance with applicable legal regulations.